

CAUTION : Read instructions thoroughly and completely prior to beginning installation.

Installation instructions for separable tee connector - type C interface

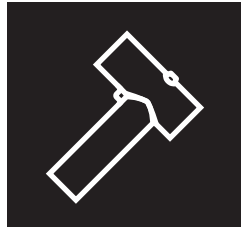









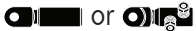

(K),(M),(P)480TB/G

Up to 20.8/36 (42) kV

Only to be used on copper wire screened cable with extruded easy strip or bonded semi-conductive screen and conductors of copper or aluminium.

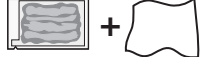
Required components for the connector installation :

 <p>3 x Tee connector housing - 480BT</p>	 <p>3 x Cable reducer 430CA-W</p>	 <p>3 x Clamping screw</p>	 <p>3 x Conductor contact - TBC-X or TMBC-X</p>	 <p>1 x Installation rod (for conductor sizes 185 up to 300 mm²)</p>
 <p>3 x Basic insulating plug + cap - 800BIPA</p>	 <p>Water sealing mastic, type MWS (outdoor applications)</p>	 <p>Field control mastic, type MFC-RLT</p>	 <p>Roll adhesive tape</p>	 <p>Silicone grease + wipers</p>
 <p>Gloves</p>	 <p>Installation instructions</p>			

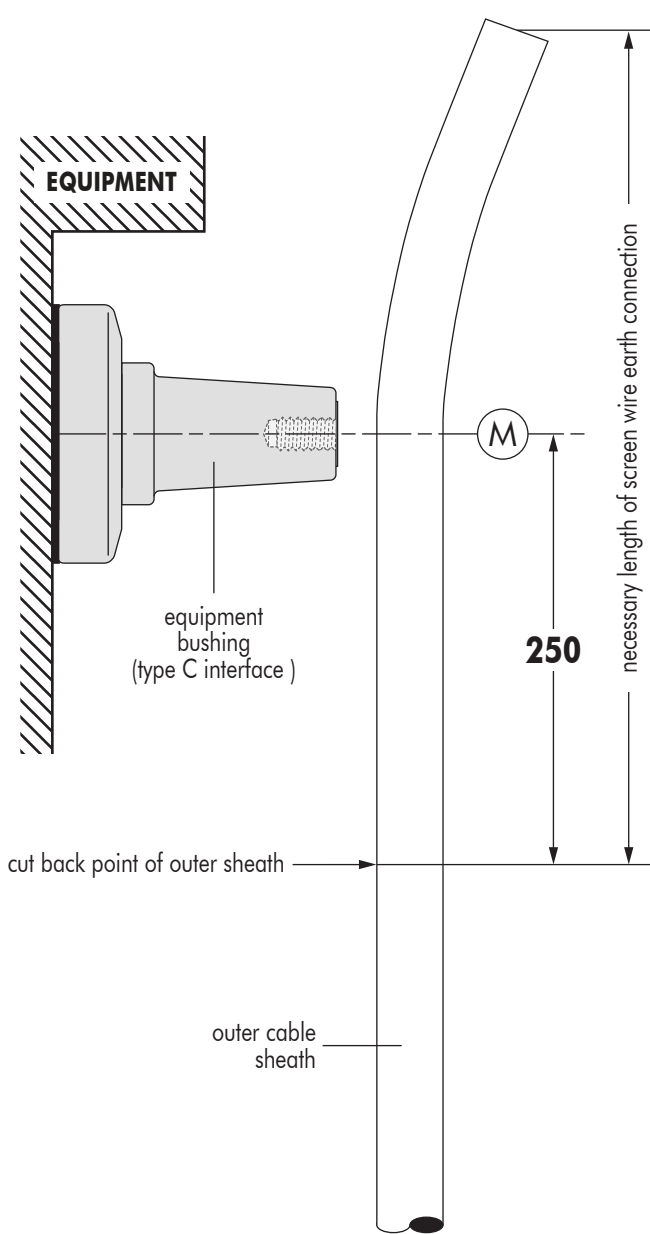

- 1 Train the cable into the approximate finished position next to the equipment bushing. Be sure to allow enough extra length of concentric wires to connect to earth.
- 2 Mark centre line « M » of the bushing.
- 3 Remove the outer cable sheath to a point **250** mm from the centre line « M » of the bushing.

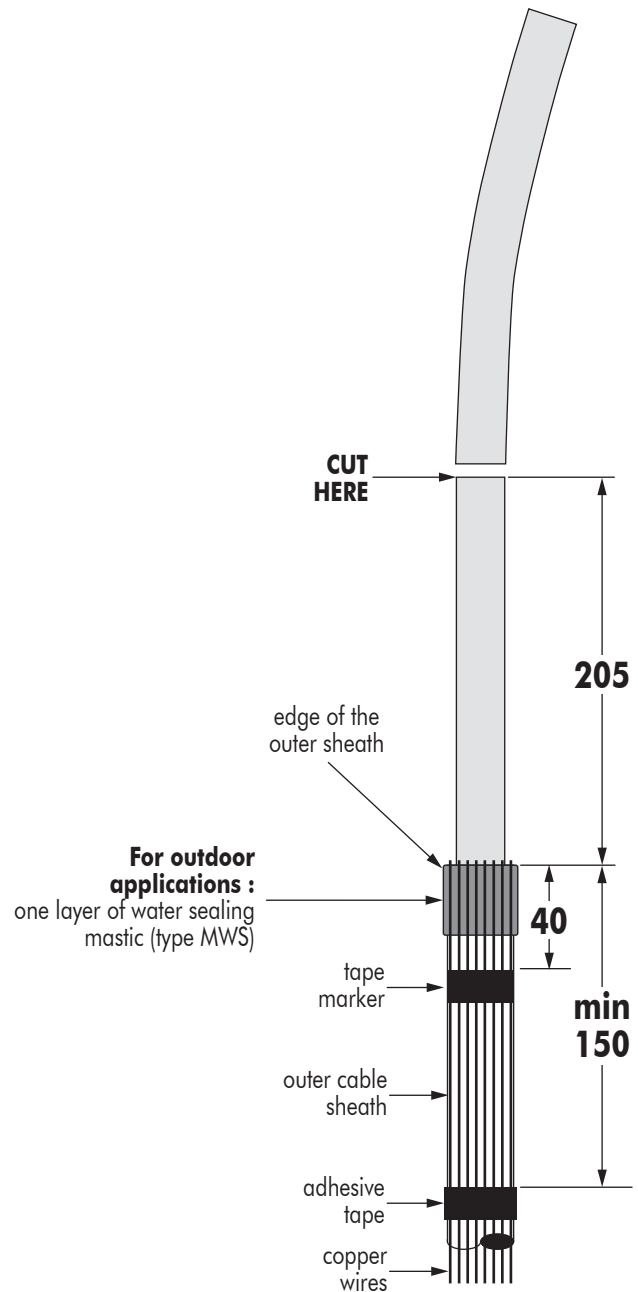

- 4 Apply a tape marker around the outer sheath **40** mm from the edge. For indoor applications, bend the screen wires back over the outer sheath and proceed to step no. 5.
For outdoor applications:
 - Wrap one layer of water sealing mastic (type MWS) around the outer sheath, flush with the end (**25** mm minimum width). Completely encircle the cable.
 - Bend the screen wires back over the mastic and along the outer sheath, pressing them into the mastic.
 - **Important:** screen wires should not touch each other when pressed into the mastic to prevent water ingress.
- 5 Using adhesive tape, fix the screen wires at a distance of min **150** mm from the edge of the outer sheath.
- 6 Cut the cable to a point **205** mm from the outer sheath.

CABLE PREPARATION

For extruded easy strip semi-conductive screen

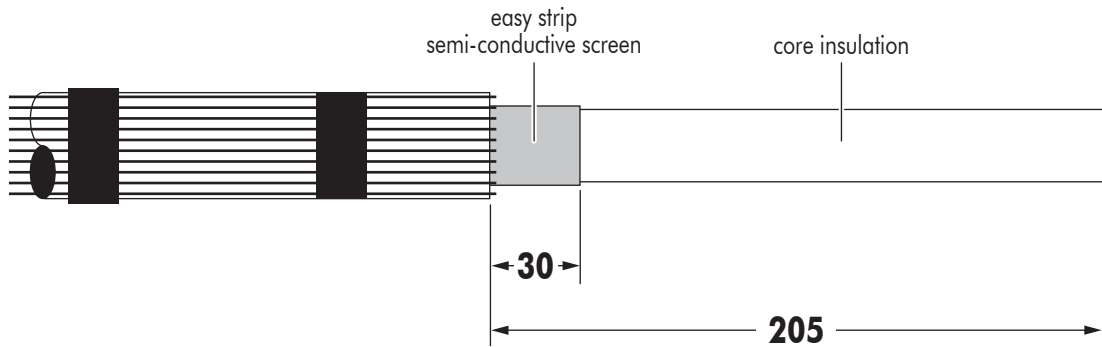

- 1 Check distance of **205** mm.
- 2 Remove the easy strip semi-conductive screen to a point **30** mm from the outer sheath. Cut squarely taking care not to cut the core insulation.

For bonded extruded semi-conductive screen

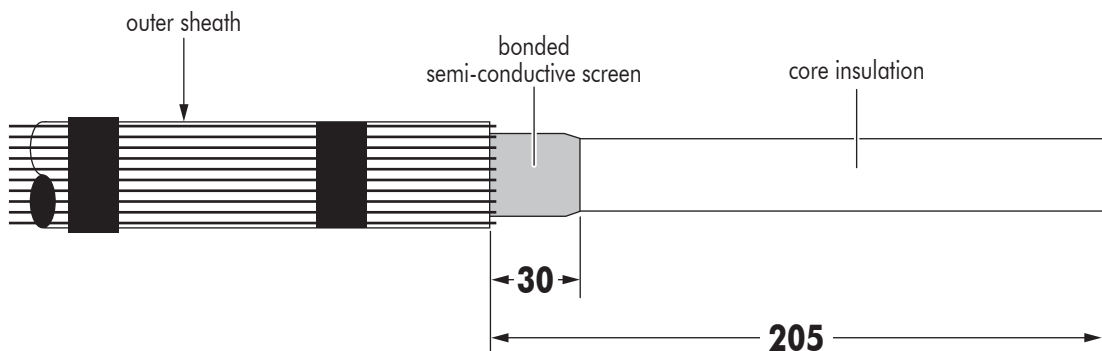

- 1 Check distance of **205** mm.
- 2 Remove the bonded semi-conductive screen to a point **30** mm from the outer sheath. Use an appropriate pencilling tool. Make a smooth transition between core insulation and semi-conductive screen.
- 3 **Remove any traces of conductive residue from the core insulation.**

REMOVAL OF THE CORE INSULATION

A. Compression type contacts (Type TBC-X)

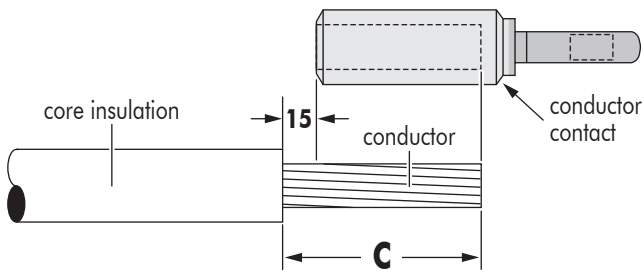

- 1 A. Remove the core insulation from the conductor for a distance « C » mm (C = depth of contact bore + 15 mm).

B. Mechanical type contacts (Type TMBC-X)

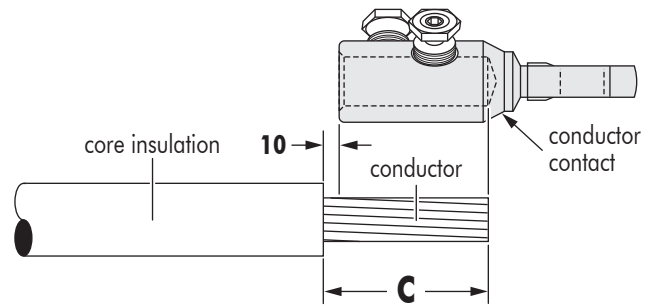

- 1 B. Remove the core insulation from the conductor for a distance « C » mm (C = depth of contact bore + 10 mm).

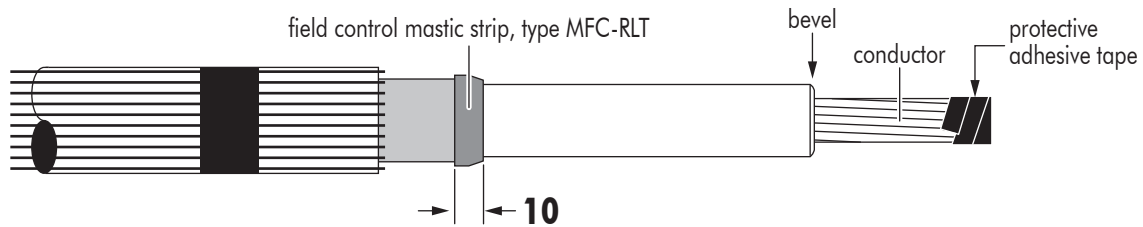

- 2 Slightly bevel the edge of the core insulation (max 2 mm). **Do not sharpen in cone-shape.**
- 3 **Thoroughly clean core insulation.** Always wipe towards the screen wires.
- 4 As a protection, wrap a few turns of adhesive tape around the conductor end.
- 5 Remove field control mastic strip, type MFC-RLT, from coated paper. Apply the mastic on the cutback edge of the semi-conductive screen, covering approximately 5 mm of the extruded semi-conductive screen and 5 mm of the core insulation. Push the mastic in place while stretching it progressively until both ends overlap and tear-off the excess mastic. Using the coated side of the paper, squeeze the mastic tightly in place on the step of the semi-conductive screen.

INSTALLATION OF THE CABLE REDUCER

For conductor sizes 35 up to 150 mm²

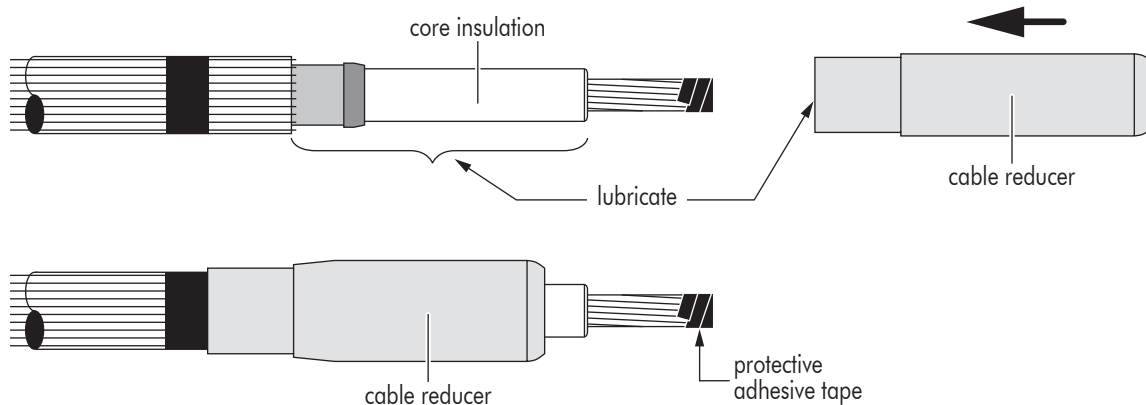

- 1 Lubricate* the indicated area : core insulation, mastic, semi-conductive screen and inner surface of the reducer.
- 2 Slide the reducer down the cable until flush with the tape marker.
- 3 Remove the protective adhesive tape from the conductor.

For conductor sizes 185 mm² up to 300 mm²

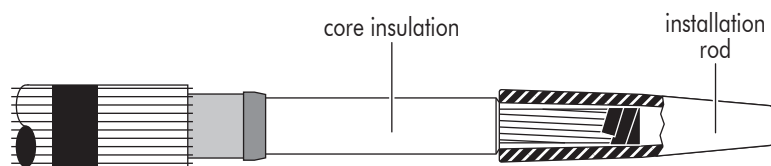

- 1** Slide the installation rod on to the conductor until it butts against the core insulation.

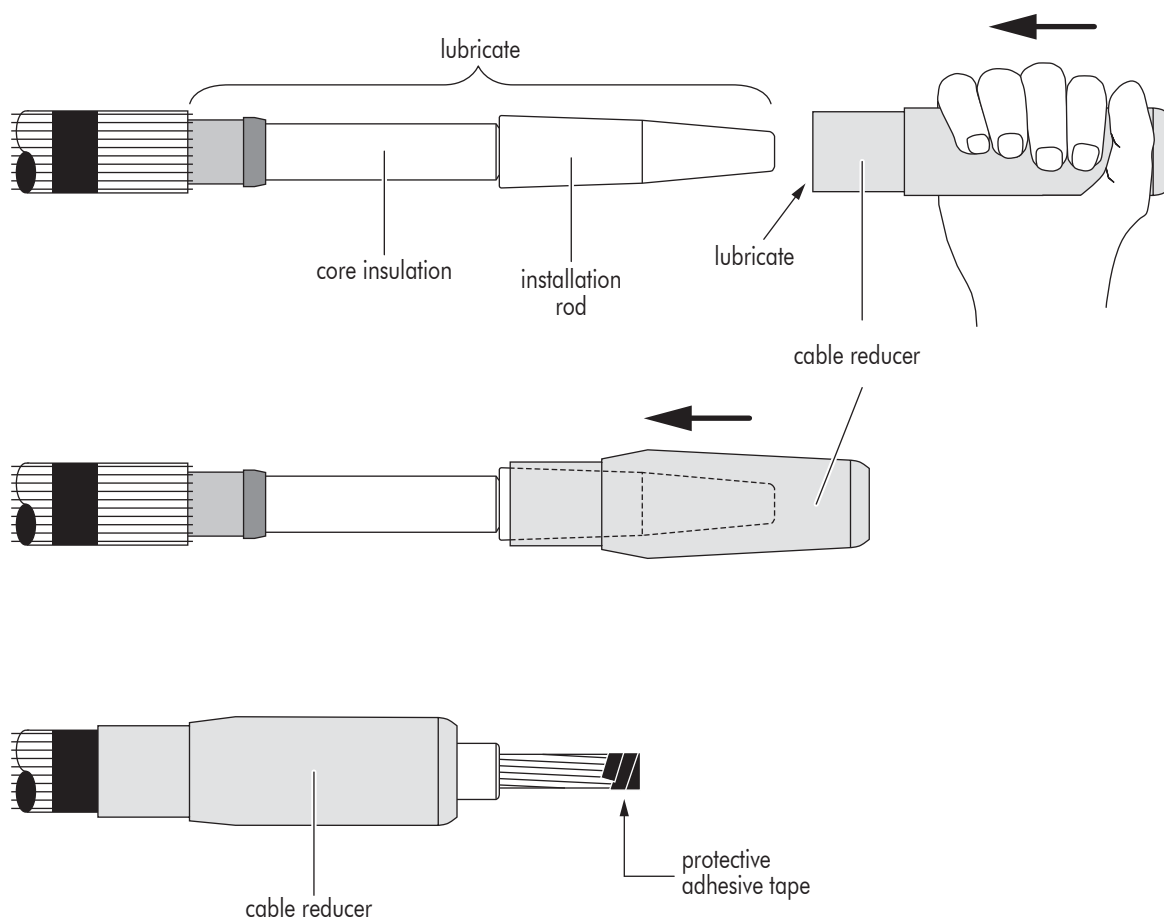

- 2** Thoroughly clean installation rod and core insulation. Always wipe towards the screen wires.
- 3** Lubricate* the indicated area : installation rod, core insulation, mastic, semi-conductive screen and inner surface of the reducer.
- 4** Slide the reducer on to the installation rod.
- 5** Slide the reducer down the cable until flush with the tape marker. Take care to slide the reducer without hesitation and in one smooth move.
- 6** Remove installation rod and protective adhesive tape from the conductor.

CRIMPING/TIGHTENING OF THE CONTACT

A

Compression type contacts (Type TBC-X)

Please refer to the crimp chart supplied with the contact.

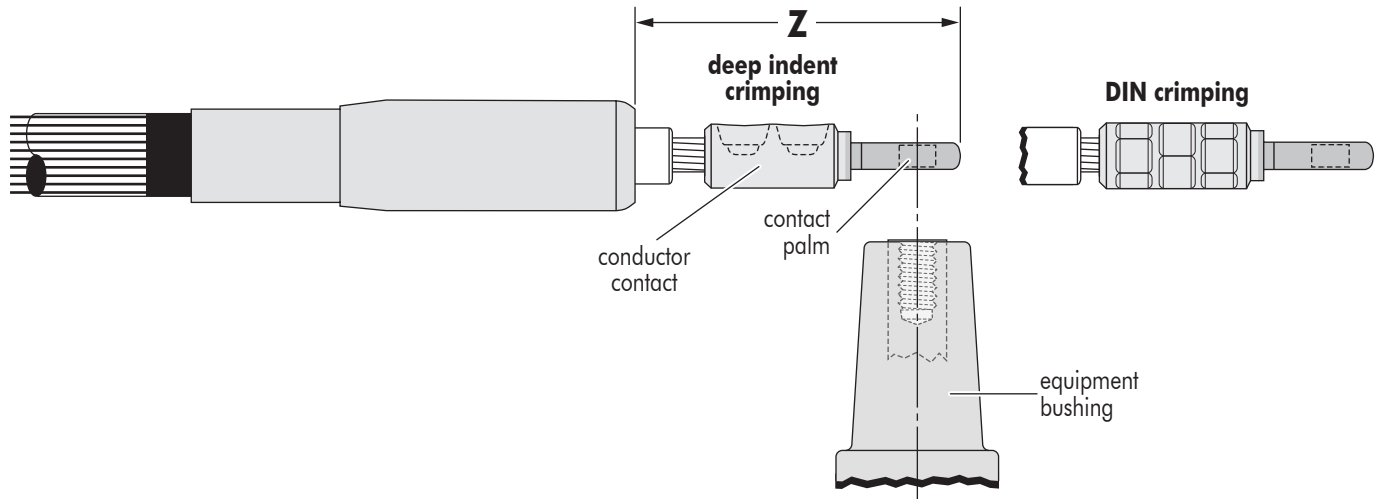

- 1 For aluminium conductors : before installing the conductor contact, wire brush the conductor.
- 2 Fit the contact on to the conductor.
- 3 Position the crimp contact taking care that the contact hole aligns with the bushing hole.
- 4 Prior to crimping distance « Z » must be between **155** and **165** mm.
- 5 Crimp the contact. Please refer to the crimp chart for crimp sequence.
- 6 After crimping distance « Z » must be between **155** and **165** mm.
If necessary, adjust the position of the cable reducer until distance « Z » is within the tolerance range.
- 7 **Remove any burrs left after crimping and wipe-off excess inhibitor.**

B

Mechanical type contacts (Type TMBC-X)

Before tightening

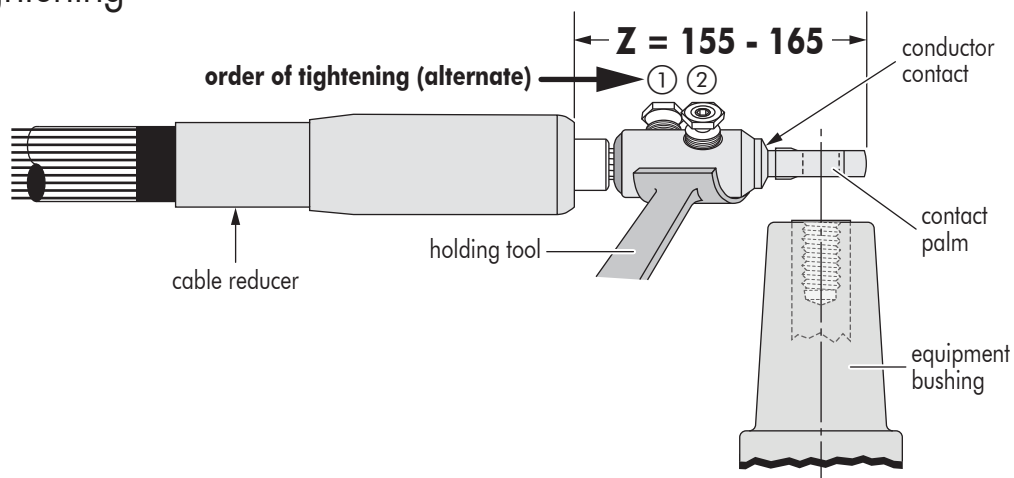

- 1 For aluminium conductors : before installing the conductor contact, wire brush the conductor.
- 2 Insert, if necessary, the centre ring into the contact barrel according to the table in the contact installation instruction.
- 3 Position the contact so that the contact hole aligns with the bushing hole.
- 4 Before tightening, distance « Z » must be between **155** and **165** mm.
- 5 Tighten the contact. Please refer to the installation instruction included with the contact.

After tightening



- 6 After tightening, distance « Z » must be between **155** and **165** mm.
If necessary, adjust the position of the cable reducer until distance « Z » is within the tolerance range.

CONNECTOR INSTALLATION ON CABLE

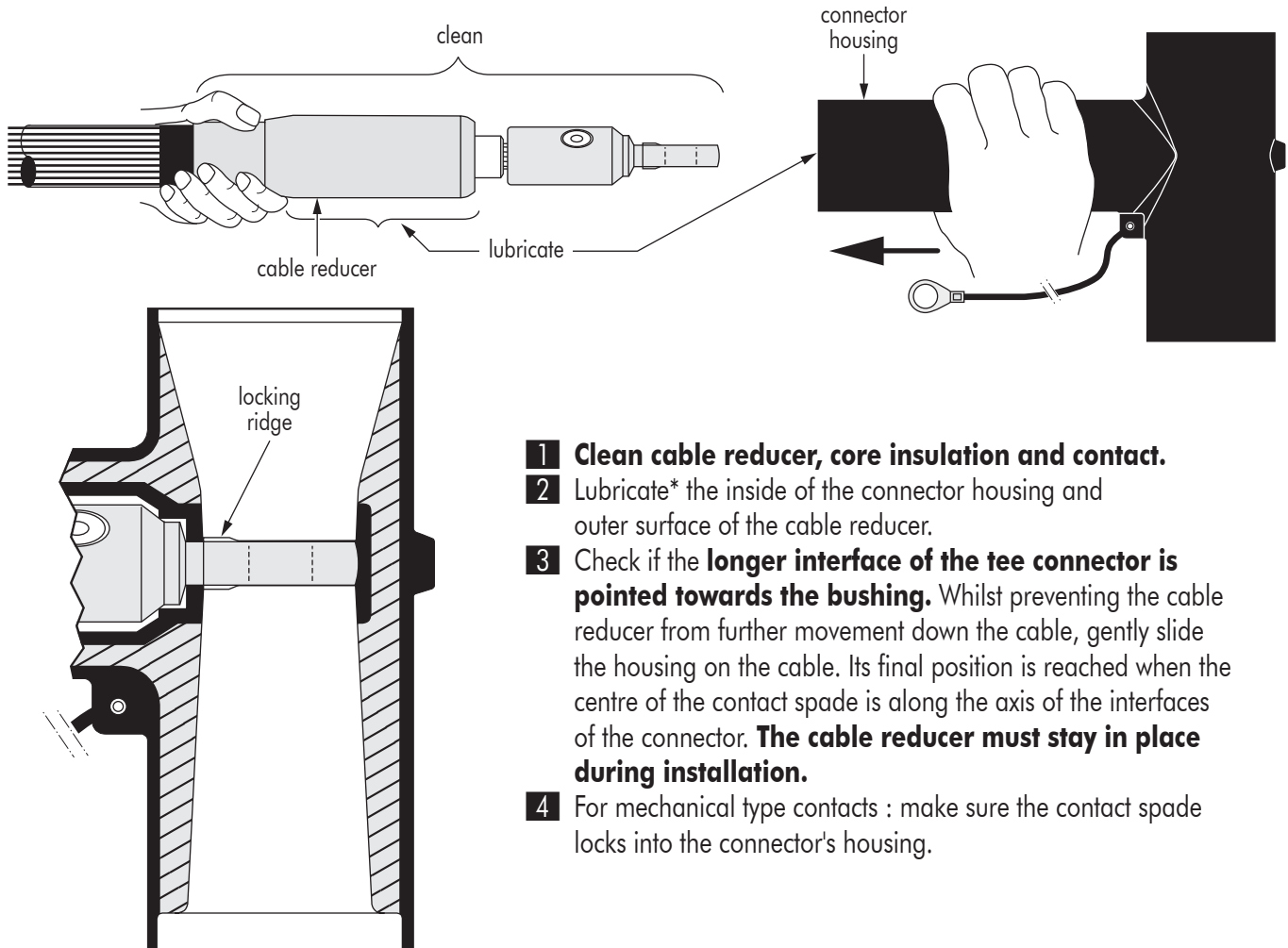

- 1 Clean cable reducer, core insulation and contact.**
- 2** Lubricate* the inside of the connector housing and outer surface of the cable reducer.
- 3** Check if the **longer interface of the tee connector is pointed towards the bushing**. Whilst preventing the cable reducer from further movement down the cable, gently slide the housing on the cable. Its final position is reached when the centre of the contact spade is along the axis of the interfaces of the connector. **The cable reducer must stay in place during installation.**
- 4** For mechanical type contacts : make sure the contact spade locks into the connector's housing.

CONNECTOR INSTALLATION ON BUSHING

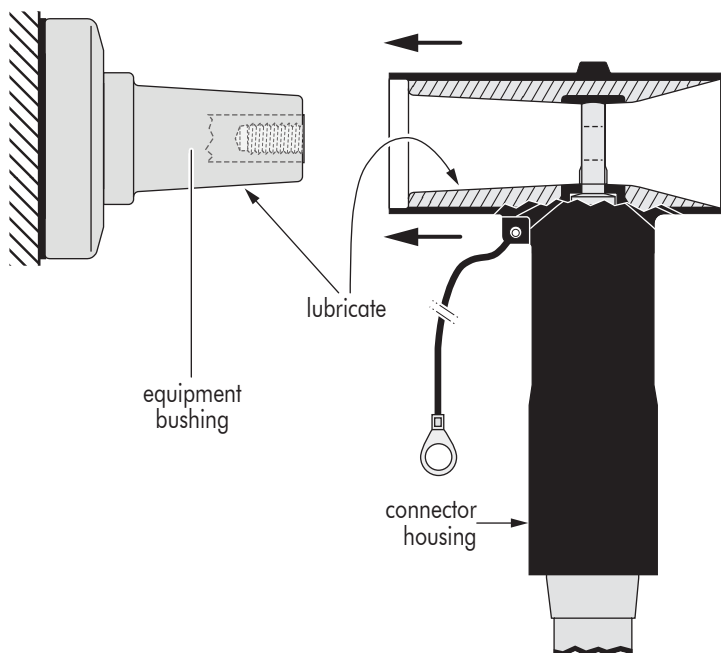

- 1** Clean and lightly lubricate* both connector and bushing interface.
- 2** Push the connector on to the bushing.

* USE ONLY THE SILICONE LUBRICANT SUPPLIED

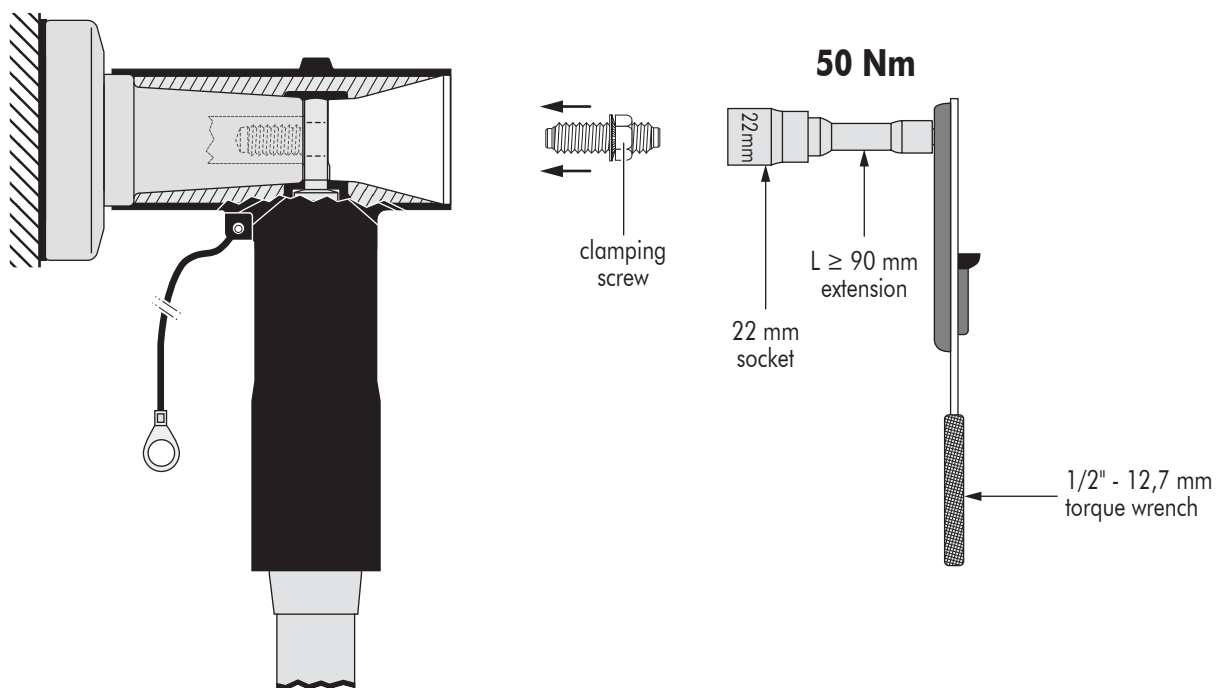

- 3 Insert clamping screw into the threaded hole of the bushing.
- 4 Use a torque wrench with a socket wrench 22 and tighten exerting **50 Nm** (5 kgm or 36,9 foot-pounds) of torque. **In order to achieve the correct applied torque ensure that there is no lubricant on the threaded parts.**

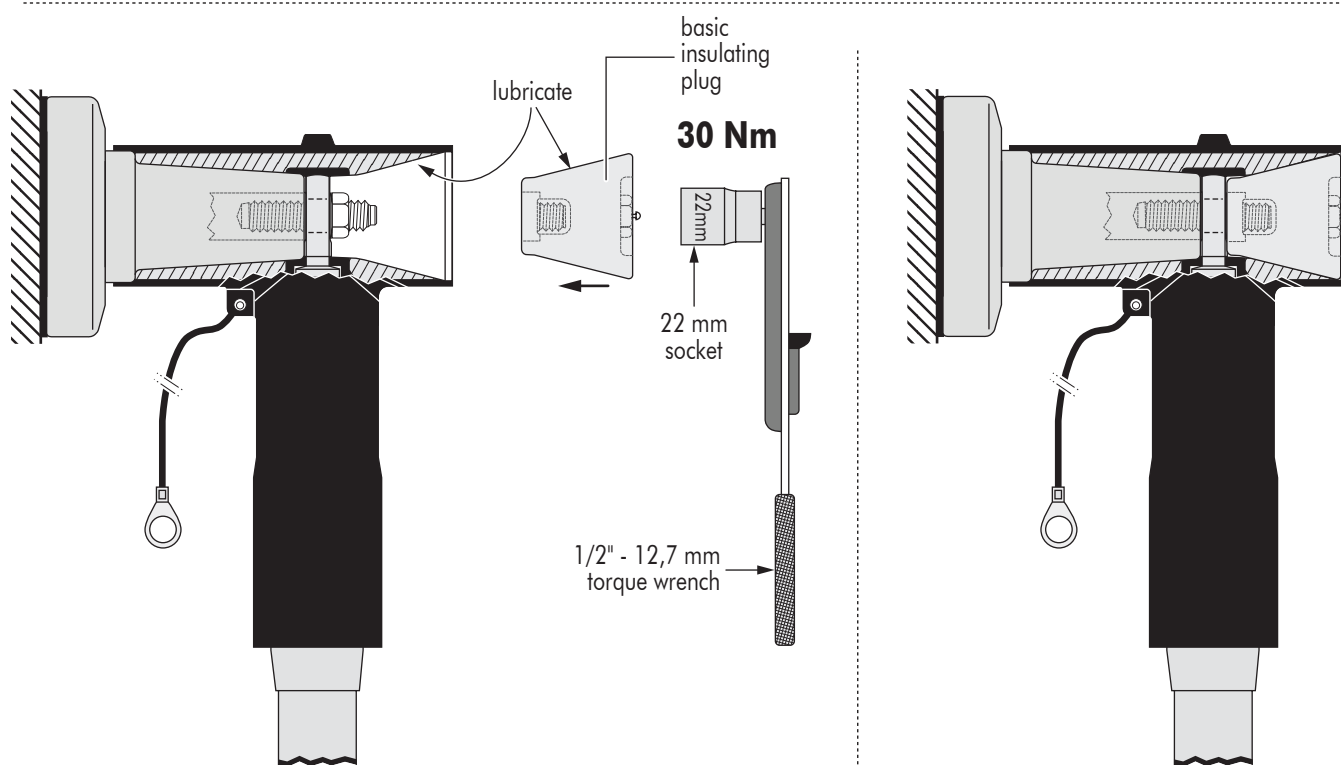

- 5 Clean and lubricate* the insulating plug for the opposite side of the connector.
- 6 Insert the plug in the connector and tighten assembly : use torque wrench with socket of 22 and tighten exerting **30 Nm** (3 kgm or 22,1 foot-pounds) of torque. **In order to achieve the correct applied torque ensure that there is no lubricant on the threaded parts.**

* USE ONLY THE SILICONE LUBRICANT SUPPLIED

INSTALLATION OF THE CAP

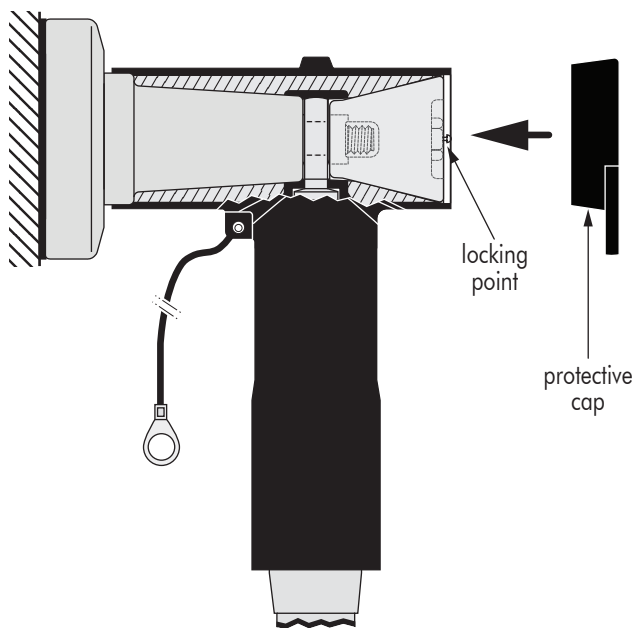

Installation on insulating plug :

Clean inside of the cap and outside surface of connector and insulating plug. Push cap over the connector and on to the insulating plug. Slightly pull up the edge of the cap to exhaust the air during assembly and while pressing the centre of the cap on to the locking point until it snaps in place. Position the cap with the pulling tab pointing downwards.

CONNECTOR EARTHING AND CABLE CLAMPING

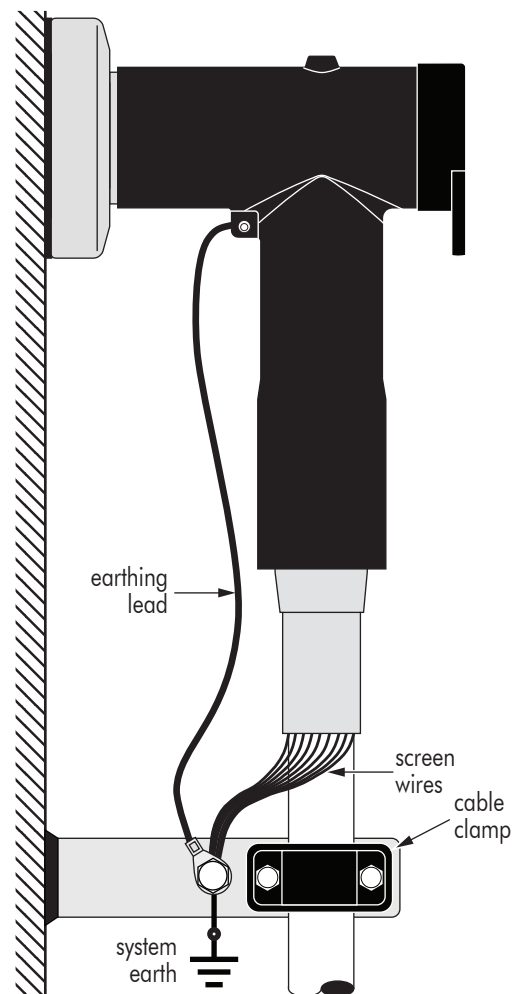

- 1 Bend back the screen wires along the outer sheath to form a pig tail.
- 2 Connect the earthing lead and screen wires to the system earth.

NOTE :

A connector/bushing mated combination should not be allowed to carry the full weight of the cable.

Therefore clamp the cable as close as possible to the connector.

IMPORTANT NOTES :

- **Never disconnect the connector from energised equipment nor energise a disconnected connector without previously installing on its appropriate corresponding mating part.**
- **Do not allow hydrocarbon oils or solvents to contaminate the E.P.D.M. rubber. In the event of contamination, wipe the surface clean with a dry cloth.**

Euromold
a Nexans company

Nexans Network Solutions NV - div. EUROMOLD

Zuid III - Industrielaan 12
B-9320 EREMBODEGEM-AALST - BELGIUM
Tel: +32 (0)53/85 02 11 - Telefax: +32 (0)53/83 10 13
sales.euromold@nexans.com